

### Dock Survey Sheet

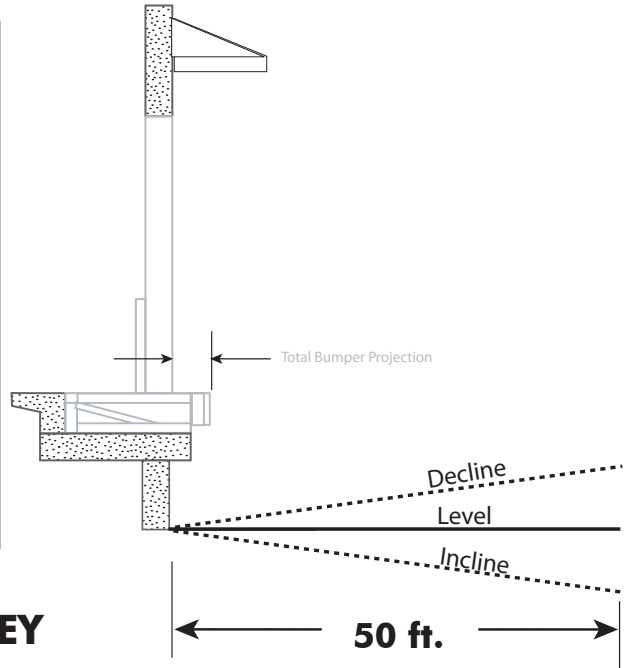
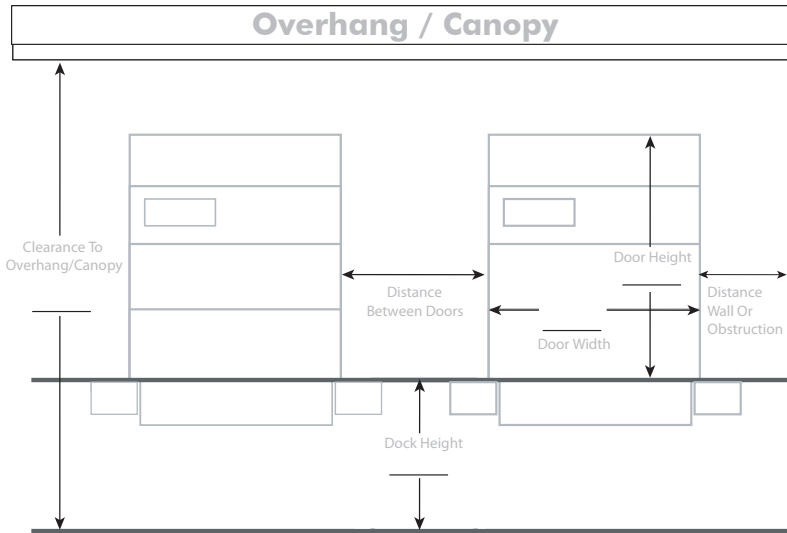

### CHALFANT SEALS AND SHELTERS SURVEY

Approach:  Level  Declined  Inclined Change In Drive Elevation In 50'0" \_\_\_\_\_

Clearance To Underside Of Overhang/Canopy From Drive \_\_\_\_\_

Distance Between Doors \_\_\_\_\_ Building Wall  Block  Precast  Metal Siding  Freezer Wall Depth \_\_\_\_\_

\*Note Any Obstructions In Job Notes And Above Drawing \* Building Wall Projection Past Face Of Dock Wall \_\_\_\_\_

Door Size \_\_\_\_\_ " Wide x \_\_\_\_\_ " High

Dock Height \_\_\_\_\_ Dock Bumper Projection \_\_\_\_\_ " Plus Wall Set Back \_\_\_\_\_ " Total Bumper Projection \_\_\_\_\_ "

**NOTES:** \_\_\_\_\_

| FAX COMPLETED SURVEY TO CHALFANT 216-521-9922 |                 |
|---|-----------------|
| DATE: _____                                   | QUANTITY: _____ |
| PROJECT NAME: _____                           |                 |
| DISTRIBUTOR: _____                            |                 |
| PHONE: _____                                  | FAX: _____      |
| SITE CHECK BY: _____                          |                 |

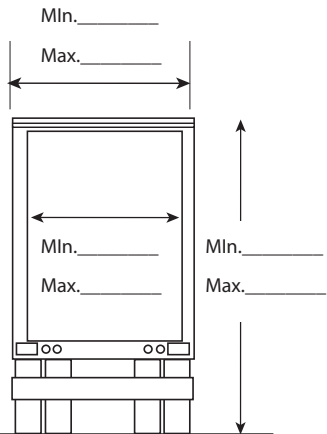

#### Truck Survey

Estimated Number Trucks Per Day Per Position \_\_\_\_\_

Number Of Shipping/Receiving Shifts Per Day \_\_\_\_\_

Maximum Unit Load Handled \_\_\_\_\_

Width \_\_\_\_\_ Height \_\_\_\_\_

Is The Load Double Stacked At The Rear Of Truck?

Yes  No

**WARNING!** Spotted Trailers/Yard Jockeys Can Create A Decline Slope When Switching Occurs. Improper Dock Bumper & Dock Seal Projection May Damage Building And Injury May Occur.

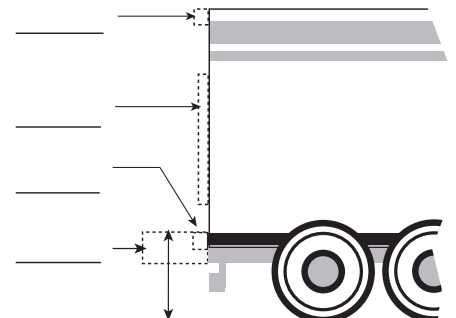

Chalfant Offers: Dock Seals, Shelters, Hoods, Rail Shelters, Recovers, Docklevelers, Edge-Of-Docks, Bumpers, Impact Doors, Air Curtains, Dock Lights, Strip Curtains